

S.00

SH 00

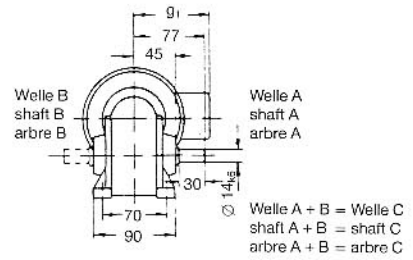

SV 00

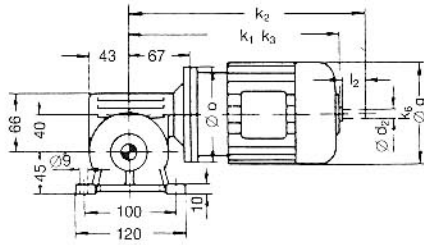
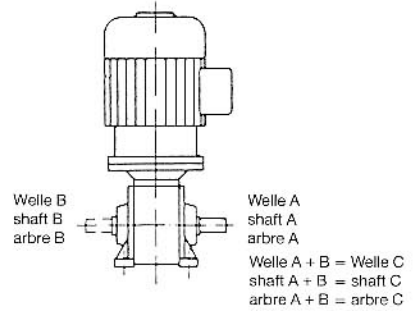
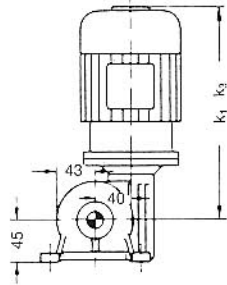

SB 00

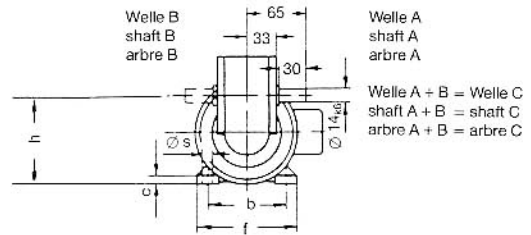
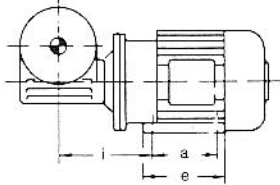

SF 00

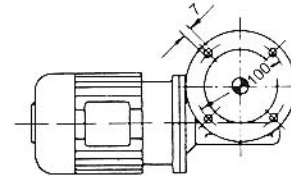
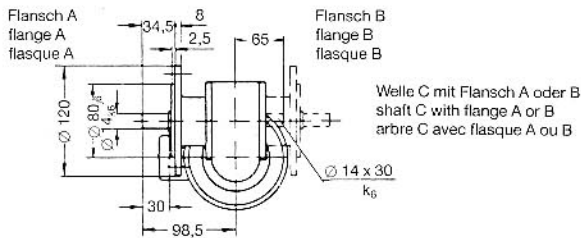

SAD 00

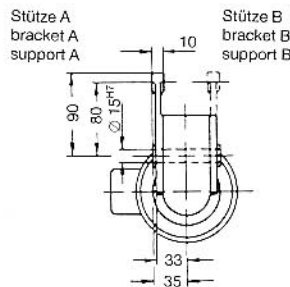

Stütze in Stellung A, B oder C  
bracket in position A, B or C  
support en position A, B ou C

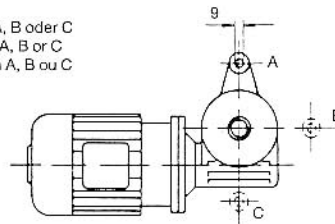

SAF 00

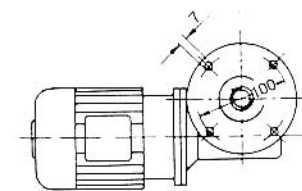
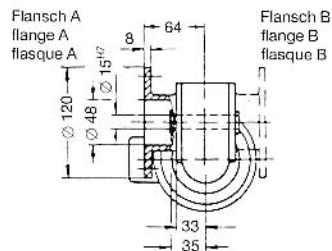

<sup>1)</sup> Nur für Bremsmotoren  
For brakemotors only  
Seulement pour moteurs-frein

<sup>2)</sup> Motoren K und N haben gleiche Abmessungen  
Motors K and N have the same dimensions  
Dimensions identiques pour moteurs K et N

Motor-Typ	a	b	c	d <sub>2</sub>	e	f	g	g <sub>1</sub>	i	k <sub>1</sub>	k <sub>2</sub>	k <sub>3</sub> <sup>1)</sup>	l <sub>2</sub>	o	s	h
56 N <sup>2)</sup>	71	90	9	9	90	112	111	100	103	234	258	268	20	105	6	96
63 N <sup>2)</sup>	80	100	10	11	105	125	123	106	107	255	283	313	23	90	7	103
71 N <sup>2)</sup>	90	112	11	11	108	140	138	115	112	279	307	340	23	105	7	111